

Lovells

Introduction to PRC Patent Practice

Geoffrey Lin
Lovells

October 2009

Summary

1. An Introduction to Patent Litigation in China
2. Utility Model Patents - A Lesser Known Chinese Patent Weapon and the Schneider Case
3. Practical Patent Strategies in Light of the New Chinese Patent Laws

Introduction to Patent Litigation in China

Geoffrey Lin
Lovells

Summary

- Laws prohibiting patent infringement exist in China and the Court System is becoming more experienced in trying such cases.
- Case in China are challenging with Evidence King and Discovery limited.
- China is and is becoming an ever increasingly strategic forum as most companies have high exposure here
- China fits into the Multi-jurisdictional landscape. (pressure in China/publicize exposure/use discovery mechanisms from actions in other jurisdictions).

Patent Litigation in China

- Chinese patent litigation system very different from US
 - No rule of binding precedent
 - No jury trials
 - Infringement and validity are tried separately
 - Burden of proof is high
 - PRC Courts rely principally on documentary evidence and require notarization and legalization for overseas evidence
 - Oral evidence is extremely rare
 - No oral or written discovery
 - Every element of claim must be proved by plaintiff—no burden shifting except for product by process claims where product is new.
- Modeled on Germany system
 - Differences in applications, more conservative and less inferences

Bifurcated System

- Infringement and validity tried separately by different bodies
- Infringement cases heard by People's Court
 - Jurisdiction determined by location of defendant or place of infringing activity
 - Jurisdiction major issue in patent infringement litigation
 - Local protectionism
 - Inexperienced courts
 - 71 courts now have jurisdiction over patent cases

Litigation - Forum Shopping

- Forum shopping
 - Consider carefully the forum to bring action
 - Beijing and Shanghai have better courts, but busy
 - Local protectionism
 - Where can infringing products be found?



The Courtroom



Patent Invalidation Proceedings

- Patent invalidity proceedings are heard by Patent Review and Adjudication Board ("PRAB") in Beijing
 - PRAB has good reputation
 - Decisions take 1-3 years
 - Criteria similar to the US:
 - Lack of novelty, inventiveness or practical applicability
 - No best mode requirement
 - No duty of candor
 - Points to note
 - Objective integer by integer analysis done for inventiveness and obviousness
 - Can be hard to prove prior use and non-patent prior publication
 - No post grant amendment (other than merging and deleting claims) allowed
 - Court proceedings for invention patent are usually not stayed pending a PRAB decision; for utility models, proceedings usually are stayed

Burden of Proof on Plaintiff

- Heavy burden of proof
 - Documentary evidence is key
 - Oral evidence considered unreliable
 - Given low weight in judgments
 - Every element of claim must be proven to high burden
 - Rarely shift burden or make inferences—even when logical or reasonable
- Documents from overseas must be notarized and legalized
 - Time consuming process
 - Must be prepared well in advance

No Discovery

- No oral or written discovery in China
- Possible to obtain “evidence preservation order” from the Court
 - Requires defendant to produce certain documents
 - No effective sanctions for non-compliance
- Burden of proof remains on Plaintiff even if an evidence preservation order is not complied with by the defendant.
- Expert Evidence
 - Expert evidence can be filed
 - The court can also appoint its own expert panels to consider if there is infringement.
 - Testing evidence is accepted
- Evidence from other jurisdictions can be used
 - US 1782 Application
 - UK – Statutory Search Order; documents once used in open court public
 - Germany and Italy (Briefs filed in Court public)
 - France – Saisie
 - Hong Kong – Anton Pillar

Claim Interpretation

- Patent law silent on key issues:
 - Claim interpretation
 - Application of doctrine of equivalents
 - File wrapper estoppel
- Chinese courts have issued interpretations and guidance on these matters
 - Claims should be interpreted in a way similar to Article 69 of European Patent Convention
 - Scope of protection based on claims with drawings and specifications used to clarify claims
 - Doctrine of equivalents can be applied
 - File wrapper estoppel
 - Estoppel—Plaintiff can not assert a reading of the patent that was specifically disavowed during prosecution

Remedies

- Preliminary injunctions – available but rare
- Final injunctive relief granted with finding of infringement
- Damages traditionally low (however Schneider 48M USD, Holley v. Samsung 7M USD, G2000 2.9M USD, cf. Neoplan Bus 3M USD and Yamaha 1.17 M USD)
 - lost profit
 - infringer's gain
 - reasonable royalty
- An appeal stays enforcement of judgments

PRC IPR Verdict Comparison

Millions (Dollars)

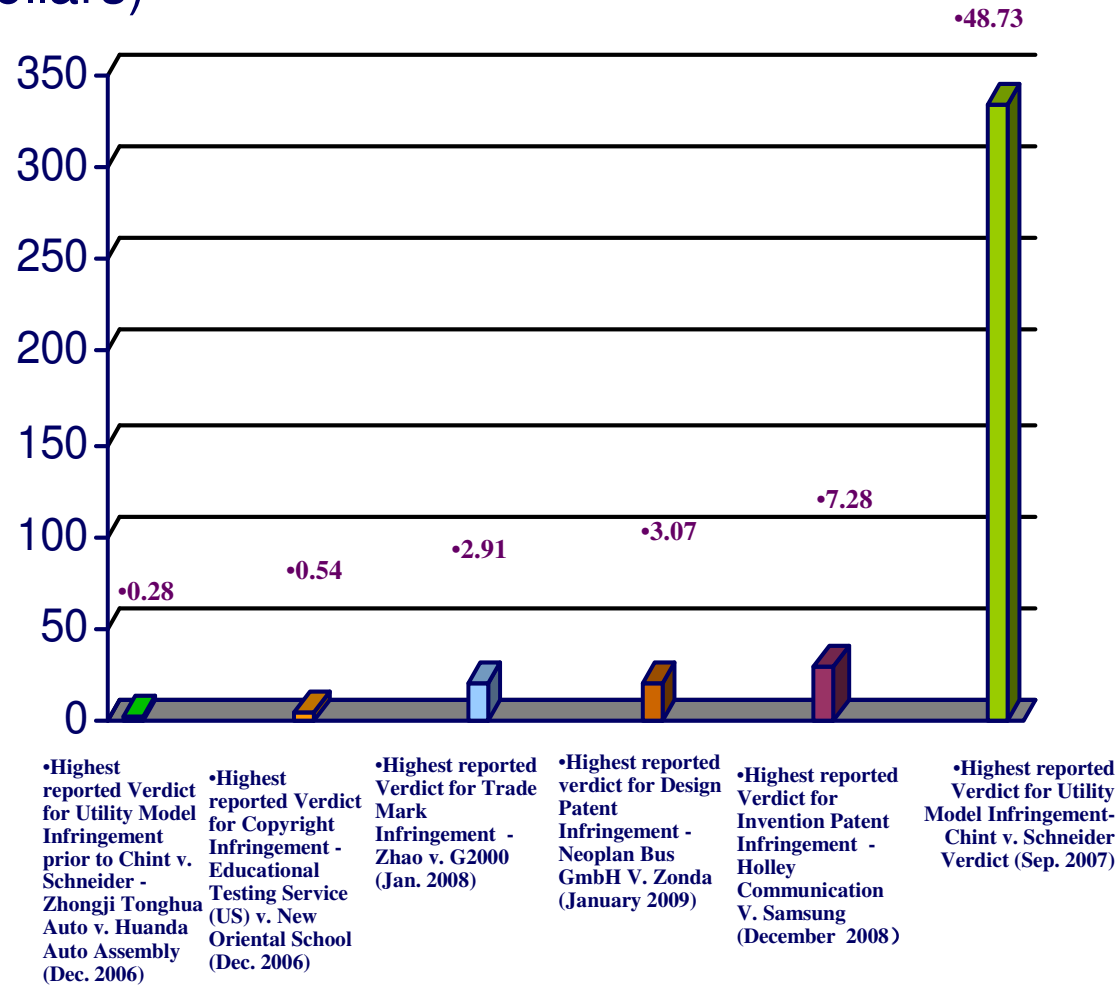

Summary

- Every element of infringement must be proven to a very high standard
 - Requires collection of evidence, testing and submission of expert evidence
- Lack of discovery adds to the difficulty of building a case
- Despite difficulties, many foreign companies are bringing and winning patent infringement cases in China
- Good knowledge of PRC patent law is essential

How to win the patent cases in China

- Plaintiff
- Remember the WIN formula: **WIN = E³ + P³**
 - That is to win you need:
 - Evidence x Evidence x Evidence
 - Preparation x Preparation x Preparation
 - Due to strict burdens of proof often search for, present and argue significant corroborating evidence or arguments
- Defendant
- Play the evidence game – concede nothing
- Know and have prepared prior art:
 - Invalidation actions must be filed quickly
 - Prior art defence has been adopted
- Identify potential attackers so as to be ready for counter attack.

Utility Model Patents - A Lesser Known Chinese Patent Weapon and the Schneider Case

Geoffrey Lin
Lovells Shanghai

Categories of Chinese Patents

- Invention Patents
 - Inventions
- Utility Models ("mini patents")
 - Minor inventions involving shapes and structures; no substantive examination.
- Design Patents
 - Industrial designs

Utility Models – Subject Matter

- Shape and structure only, and the applicant cannot claim a method, function, ingredients, or chemical composition.

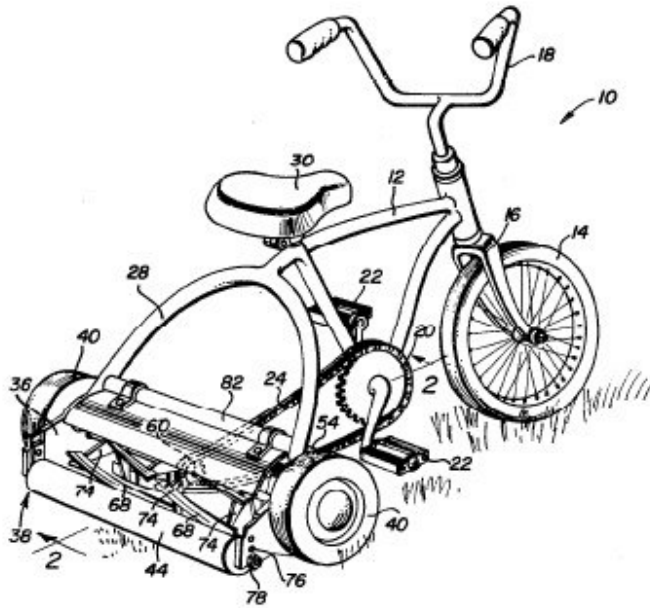

Utility Models – Standard for Grant

- Lower requirement for inventiveness according to the Chinese Patent Law.
 - "substantive features and progress" instead of
 - "prominently substantive features and notable progress" required for inventions
 - which means you must use 2 or 3 references at most to invalidate
- Application is only subject to procedural examination, NOT substantive examination.
- The term of protection is 10 years, instead of 20 years for invention patents.
- Issued more quickly compared to an invention patent: nine months to one year vs. as long as 3-4 years
- The costs for obtaining a UM is significantly lower: generally about half of the costs for an invention patent.
- There is guidance that UM cases should generally be stayed if an invalidation action is filed

Utility Models – Weak in theory

- In theory weaker than an invention patent in terms of validity, but injunction and damages are available.
- The record amount of damages for all IP infringement decisions in China (approx. USD47 million) has been granted for the infringement of one UM in 2007:
- The CHINT Group v. Schneider Electric Case

CHINT v. Schneider - Company Profiles

- Schneider Electric
 - Fortune 500 company, based in Paris.
 - Market leader in electric systems.
 - Completed major M&As in Europe and China.
- CHINT Group
 - Chinese manufacturer of low-voltage electric circuit breakers, based in Wenzhou, Zhejiang Province.
 - Started as a garage shop in mid-1980's and emerged as a major local player in early 2000's.
- Litigation
 - Multiple patent infringement suits between the two in Europe and China.

CHINT v. Schneider – Wenzhou Case

mid-Nov. 1997	CHINT applies for a utility model for "a miniature circuit breaker".
March 1999	CHINT obtains its utility model.
late July 2006	CHINT files its Complaint against Schneider at the Wenzhou Intermediate People's Court. CHINT initially sought 500,000 RMB in damages from Schneider.
late August 2006	Schneider applies to invalidate CHINT's utility model patent before the Patent Review and Adjudication Board (PRAB) of SIPO.
Dec. 2006	The PRAB holds oral hearings on Schneider's invalidation filed in December 2006.
late April 2007	The PRAB issues its decision upholding the validity of CHINT's utility model, with respect to Schneider's invalidation filed in late August 2006.
late- April 2007	Heard by the Wenzhou Court
late Sept. 2007	The Wenzhou Court issues its record judgment (about USD47 million).
October. 2007	Schneider appeals the Wenzhou Court's judgment to the Zhejiang Higher People's Court and appeals the PRAB decision to the Beijing Intermediate Court

Comparison of Schneider Prior Patent with CHINT UM Patent

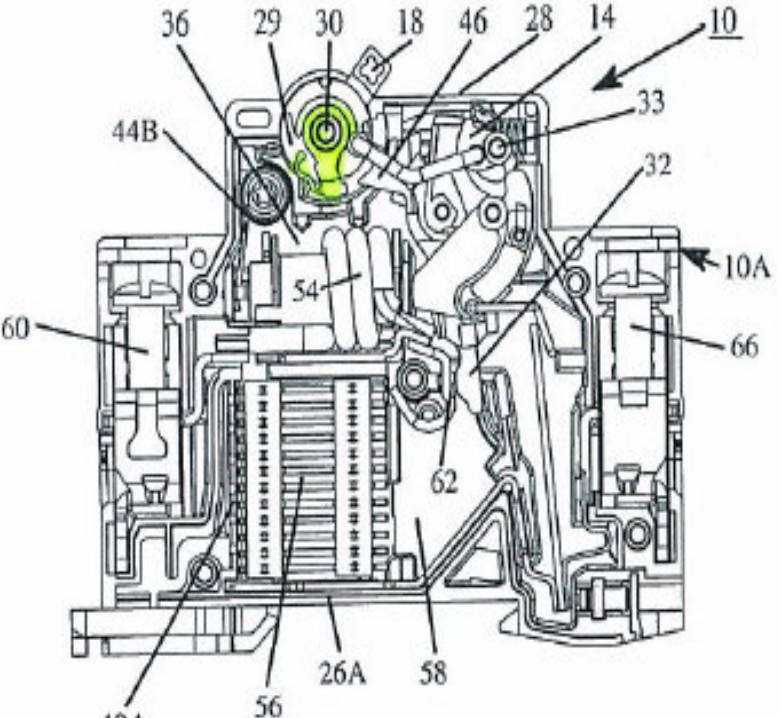
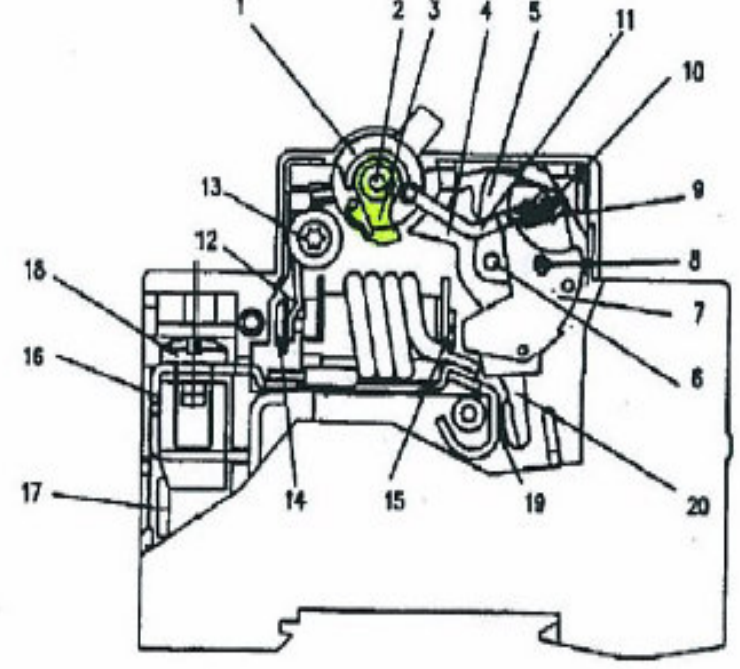
Schneider's Invention Patent ZL97125489.3 (1996 Priority Date)	CHINT's Utility Model Patent ZL97248479.5 (1997 Application Date)
 <p data-bbox="588 1282 672 1323">FIG 5</p>	 <p data-bbox="1480 1299 1564 1339">图 5</p>

CHINT v. Schneider – Wenzhou case

- Outcome (as reported by media)
 - Settled in April 2009 right before appellate trial.
 - Settlement with payment of approx. USD22 million to CHINT.
 - Worldwide settlement of all disputes.

CHINT v. Schneider – Wenzhou case

- Lessons to learn:
 - UMs ("mini patents") can be used aggressively and can be difficult to invalidate.
 - Monitor a local competitor's IP portfolio, including its UMs (file for invalidation if necessary).
 - Evidence: keep complete original records
 - Forum Shopping: Consider filing declaration of non-infringement in your selected venue first
 - Consider expanding patent portfolios in China to include more UMs and using them against competitors .
 - Consider Dual Filing
 - Expect a higher burden of proof for foreign companies.

Practical Patent Strategies in Light of the New Chinese Patent Laws

Geoffrey Lin
Lovells

Summary

- Third Amendment to the PRC Patent Law
 - passed on 27 December 2008 and effective on 1 October 2009
- The Supreme People's Court (SPC) Opinion on Certain Issues with Respect to Intellectual Property Judicial Adjudication Under the Current Economic Situation (SPC Opinion)
 - Issued 21 April 2009
- The Supreme People's Court (SPC) Draft Judicial Interpretation on Several Issues regarding Patent Infringement Cases (SPC Draft Interpretation)
 - Released on 18 June 2009 for comments from the public by 10 July 2009

Third Amendment to the PRC Patent Law

passed on 27 December 2008 and effective on 1 October 2009

Third Amendment to the Patent Law - Chronology of the Patent Law of China

- 1978 - Reform and opening
- 1984 - Patent Law enacted
- 1992 - First revision of the Patent Law
- 2000 - Second revision of the Patent Law
- 2009 - Third revision of the Patent Law, passed on 27 December 2008, will become effective starting from 1 October 2009

Confidentiality Examination requirement for inventions completed in China removed (Article 20)

- Current law: If an invention is completed in China, a Chinese applicant needs to first file an application in China.
- Revised law: Anyone can first file in a foreign country, but he/it has to go through a “confidentiality examination” by SIPO first.
 - “Confidentiality examination” only applies to invention patents and utility models but not design patents.
- Draft Implementing Regulations: if no decision within five (5) months, applicant is free to proceed with the foreign filing.
- In Practice: Necessary for international collaborative inventions
- Consider filing PCT application in China in English first to satisfy the requirement

Absolute Novelty - Higher standard of patentability for invention patents and utility model patents (Article 22)

- Current law: Unpublished prior public knowledge or use counts as prior art against a patent or application only if the relevant act occurred in China.
- Revised law: Absolute novelty: all prior public knowledge or use counts as prior art.
 - This is for both novelty and inventiveness considerations.
- In practice. It may be difficult to prove prior public knowledge or use in a foreign country to the standard most Chinese courts require.

Prior art defense (Article 62)

- Defendant is allowed to show that the technology or design that is exploited belongs to a prior art technology or prior design it will not constitute patent infringement
- In Practice:
 - Defendant can use the prior art defense only to show that the patent is not novel. The defense does not allow the defendant to argue that the patent is obvious.
 - For evidence purposes, consider filing your designs with a technical library once the product becomes public

International patent exhaustion (Article 69) and Clinical Trial Exception (Article 69)

- The revised law provides that once a patented product is sold by the patentee or an entity authorized by the patentee, there would be no infringement to use, sell, and import the product. This provision allowing parallel importation.
- No infringement if person or entity is making drugs and/or medical devices for the purposes of providing information for getting administrative approval.
 - Can make enforcement more difficult.

The Supreme People's Court (SPC) Opinion on Certain Issues with Respect to Intellectual Property Judicial Adjudication Under the Current Economic Situation (SPC Opinion)

Issued 21 April 2009

SPC Opinion Regarding Patents Generally

- Although the Opinion generally states that courts shall strengthen patent right protection to encourage investments in innovation, the Opinion further states that patent rights shall not become a burden to the advancement of technology, or a tool for unfair competition.
- i.e., "Balanced Approach" to Patent Infringement

Declaratory Judgments

- Courts may allow declaratory judgment actions under various conditions in order to restrain abuse of IP rights. (Opinion, paragraph 13.)
 - Received Warning Letter
 - Send Patentee a written request to confirm non-infringement. If no reply, can file a declaratory judgment action.
- In Practice. Consider declaratory judgments to obtain forum and stay out of patentee's home court

Damage Calculations

- The Opinion encourages the courts to make damage calculations more reasonable and convincing:
 - Damages can exceed the maximum statutory damages amount even when damages evidence is not sufficient for an accurate calculation
 - Experts can be used, e.g., accountants, auditors, professional evaluation agencies
 - When using a royalty calculation damages should be higher than typical royalties

Discretion not to grant permanent injunctions

- Courts may decide not to grant permanent injunctions (Opinion para 15):
 - great imbalance between the parties' interests
 - harming public interest
 - unenforceable in practice
- Acquiescence (failure to act):
 - another reason to deny injunctive relief is: if the IP owner knew of the infringing activities but did not take action to stop infringement for a long period of time.
- Both concepts were in the final draft but removed from the Third Amendment of the Patent Law [now reintroduced by SPC]

The Supreme People's Court (SPC) Draft Judicial Interpretation on Several Issues regarding Patent Infringement Cases (SPC Draft Interpretation)

Released on 18 June 2009 for comments from the public by 10 July 2009.

Prior Art Technology Defence (Art. 17) and Indirect Infringement

- Prior Art Defense is a Comparison between:
 - a) accused features of the accused device; and
 - b) corresponding features of ONE prior art technology.
- If (a) are identical OR equivalent to (b), the defence stands.
- Indirect Infringement
 - Patent owner can sue an indirect infringer without bringing the direct infringer into court.

Patents that are incorporated into a standard with the consent of the patent owner – court may grant compulsory licenses

- When the standard does not disclose the patent
 - Court may grant a compulsory license to parties who wish to implement the standard, and determine a reasonable amount of licensing fees.
- When the standard discloses the patent and the conditions for licensed implementation
 - The other parties who wish to implement the standard should do so in accordance with the disclosed conditions. However, if the disclosed conditions are obviously unreasonable, the court may make adjustments.
- When the standard disclosed the patent but the conditions for implementation are not disclosed or is unclear
 - In this situation, the parties may negotiate. If the negotiation is not successful, the court may determine the conditions.

For further information Please contact

Horace Lam

Lovells Beijing LLP

horace.lam@lovells.com

Tel: +86 10 6582 9488

Fax: +86 10 6582 9499

Geoffrey Lin, Counsel

Lovells Shanghai LLP

geoffrey.lin@lovells.com

Tel: +86 21 6138 1688

Fax: +86 21 62792695